

3-PC DIRECT MOUNT EA-33NF-SE/SW/BW

Features & Specifications

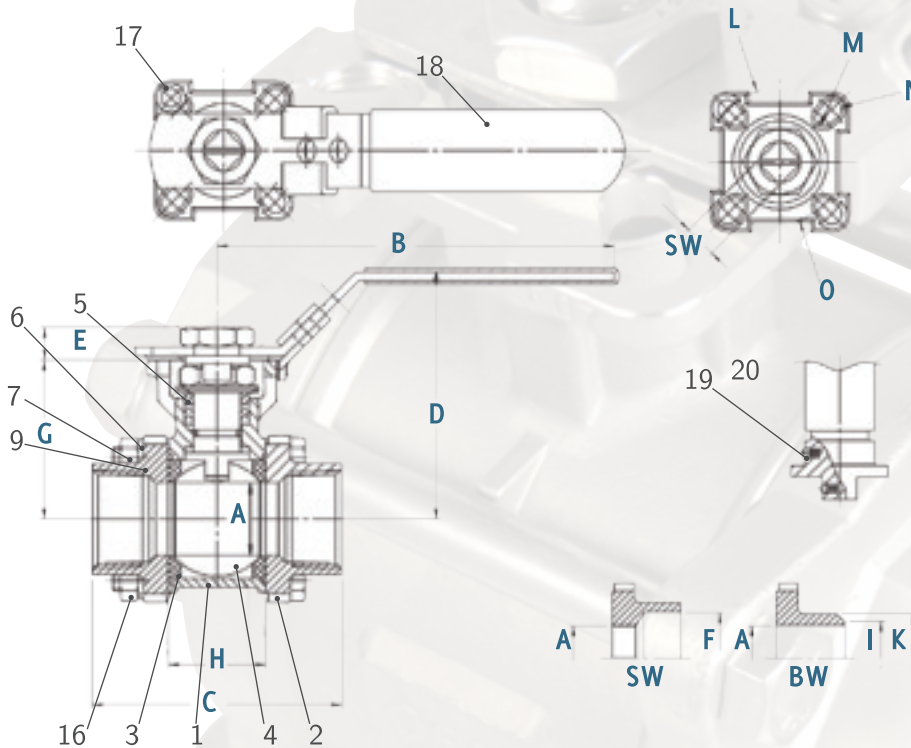

- » 3-piece 316 SS investment cast body and components
- » Maintenance free live loaded, self adjusting stem packing
- » 1000 PSI WOG rating
- » Cavity filled and regular seating available in various stocked materials: RPTFE, VPTFE, TFM1600, UHMWPE, SSTxPTFE
- » Optimum sealing for high cycle applications with V-ring chevron packing, bellville washers, and two VITON® o-rings as a secondary defense against leaking
- » Blowout proof stem full port, split body design
- » ISO 5211 direct mounting to actuator
- » Option: 150# Flanged Ends for regular & cavity filled styles
- » SE ANSI B2.1, B16.34 Threaded (NPT)
BW ANSI B16.25 Butt Weld
SW ANSI B16.11 Socket Weld



Item	Part (Qty)	Material
1	Body	CF8M/316 SS
2	End Caps (2)	CF8M/316 SS
3	Seat Stem (2)	PTFE
4	Ball	SUS 316
5	Stem	SUS 316
6	Gasket	PTFE
7	Seal	PTFE
8	Gland Ring (2)	SUS 304
9	Bellville Washer (2)	SUS 301
10	Lever Nut	SUS 304
11	Locking Tab	SUS 304
12	Handle	SUS 304
13	O-ring	VITON®
14	Bolts (4)	SUS 304
15	Bolt Nuts (4)	SUS 304
16	Spring Washer (4)	SUS 304
17	Stop Screw	SUS 304
18	Plastic Coating	Vinyl
19	Static Device (2)	SUS 316
20	Spring (2)	SUS 316

Size	A	B	C	D	E	F	G	H	I	K	L	M	N	O	SW	ISO5211
½	0.63	4.33	2.95	2.79	0.31	0.86	1.67	0.99	0.67	0.88	1.65	0.24	0.24	1.42	0.35	F03/F04
¾	0.79	4.33	3.15	2.89	0.31	1.07	1.76	1.09	0.87	1.11	1.65	0.24	0.24	1.42	0.35	F03/F04
1	0.96	5.31	3.54	3.31	0.39	1.34	2.13	1.30	1.10	1.33	1.97	0.24	0.28	1.65	0.43	F04/F05
1¼	1.26	5.31	4.33	3.52	0.39	1.68	2.33	1.62	1.46	1.73	1.97	0.24	0.28	1.65	0.43	F04/F05
1½	1.50	6.50	4.72	4.31	0.58	1.92	2.89	1.94	1.69	2.00	2.76	0.28	0.35	1.97	0.55	F05/F07
2	1.97	6.50	5.51	4.68	0.58	2.41	3.26	2.50	2.13	2.46	2.76	0.28	0.35	1.97	0.55	F05/F07
2½	2.50	11.81	7.48	6.10	0.67	3.03	4.21	3.23	2.70	3.00	4.02	0.35	0.43	2.76	0.67	F07/F10
3	3.00	13.19	8.66	6.50	0.67	3.54	4.62	3.77	3.17	3.50	4.02	0.35	0.43	2.76	0.67	F07/F10
4	4.00	13.19	10.63	7.09	0.67	45.47	5.21	4.64	4.18	4.50	4.02	0.35	0.43	2.76	0.67	F07/F10

