

2-PC HIGH PRESSURE VALVE SERIES 20/40

Features & Specifications

- » 2-piece 316 SS investment cast body
- » Locking handle
- » Sizes ¼"–1" have 2000 PSI WOG rating
- » Sizes 1¼"–2" have 1500 PSI WOG rating
- » Blowout proof stem design
- » Full ported design, NPT
- » Industrial/chemical applications
- » ANSI B2.1, B16.34

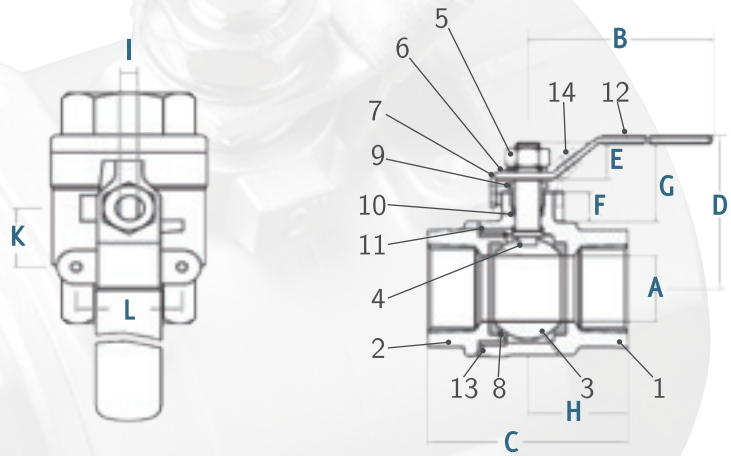

Item	Part (Qty)	Material
1	Body	ASTM A351 GR CF8M
2	Cap (2)	ASTM A351 GR CF8M
3	Ball	SUS 316
4	Stem	SUS 316
5	Stem Nut	SUS 304
6	Stem Washer	SUS 304
7	Handle	SUS 304
8	Seat (2)	PTFE
9	Gland	SUS 304
10	Stem Packing	PTFE
11	Thrust Washer	PTFE
12	Handle Sleeve	Vinyl
13	Joint Gasket	PTFE
14	Locking Device	SUS 304



Size	A	B	C	D	E	F	G	H	I	K	L
¼	0.46	3.94	2.17	1.97	0.39	0.31	0.91	1.08	0.20	0.50	1.12
⅜	0.50	3.94	2.17	1.97	0.39	0.31	0.91	1.08	0.20	0.50	1.12
½	0.59	5.12	2.56	2.56	0.47	0.39	1.02	1.28	0.26	0.50	1.12
¾	0.79	5.12	2.91	2.91	0.47	0.43	1.02	1.46	0.26	0.88	1.38
1	0.98	6.50	3.46	3.46	0.59	0.47	1.18	1.73	0.31	0.88	1.38
1¼	1.26	6.50	4.02	4.02	0.59	0.47	1.46	2.01	0.31	1.00	1.50
1½	1.50	7.48	4.33	4.33	0.63	0.47	1.38	2.17	0.38	1.00	1.50
2	1.97	7.48	4.92	4.92	0.63	0.39	1.22	2.46	0.38	1.00	1.50