

INDUSTRIAL BALL VALVES

GROOVED-END STYLE 3-PC SERIES



EA - 301 - GE

FEATURES / SPECIFICATIONS:

- ASTM 316 stainless construction
- Reinforced teflon, 3-piece "chevron" style packing - expands outward as it is compressed to seal
- Victaulic® style grooved connections
- High quality investment cast body and end caps
- Designed for quick disconnect service
- 100% air tested underwater at the factory
- Blowout proof stem design
- Locking handle is standard
- Available in 2" & 3" sizes
- Options: 3" in 8" or 10" length

SIZE	A mm	B (GE) mm	C mm	D mm	K (GE) mm	L (GE) mm	M (GE) mm	N (GE) mm
2"	50	171.45	98.7	180	60.3	57.15	7.93	15.88
3"	80	203.20	142.1	300	88.9	84.94	7.93	15.88
3" sp	8.0	254.0	142.1	300	88.9	84.94	7.93	15.88

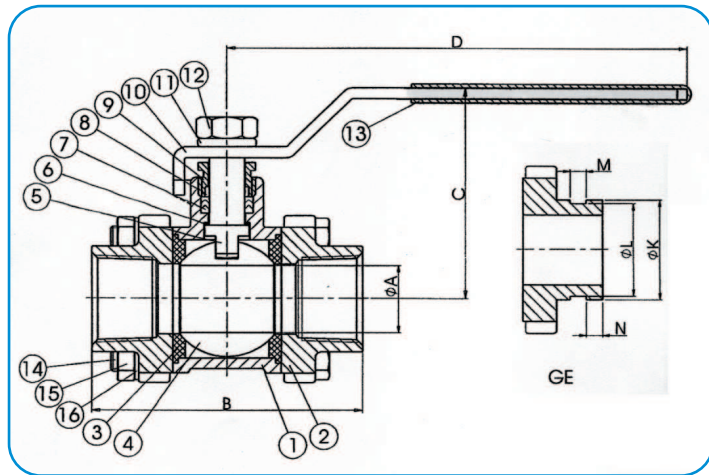

Item	Part name	Material	Qty
1	body	ASTMA351.CF8M/SS316	1
2	end cap	ASTMA351.CF8M/SS316	2
3	seats	PTFE + 15% G.F.	2
4	ball	ASTMA351.CF8M/SS316	1
5	stem	SS316	1
6	gasket	PTFE	1
7	seal	PTFE	1
8	gland bush	PTFE	1
9	packing gland	SS304	1
10	handle	SS304	1
11	lever spring washer	SS304	1
12	lever nut	SS304	1
13	handle cover	VINYL	1
14	bolts	SS304	4
15	bolt nuts	SS304	4/8
16	spring washers	SS304	4/8

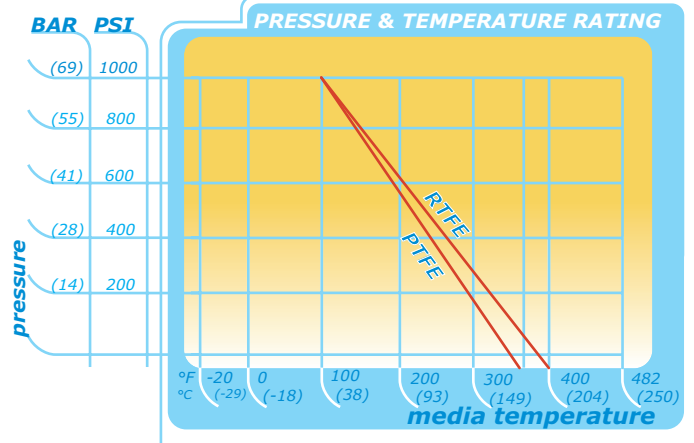

EA - 301 - GE