

INDUSTRIAL BALL VALVES

DIRECT MOUNT MULTI-PORT SERIES



Series 36

FEATURES/SPECIFICATIONS:

- ISO 5211 Direct mount pad. Allows direct mounting of pneumatic and electric actuators, no brackets and couplings needed, easy and low cost for automated service.
- Full Port, Multi port design :L&T port flow design available
- Live loaded stem packing
- Blow out proof stem, floating ball design
- Cost efficient. One valve can replace two or more valves, reduces the number of valves in piping system.
- Anti-static device
- Investment cast body construction
- 1000 PSI W.O.G.
- Sizes 1/2" - 4"

Item	Part Name	Material	Qty
1	end caps	A351 Gr. CG8M/A216 Gr. WCB	3
2	gasket	PTFE	4
3	body	A351 Gr. CG8M/A216 Gr. WCB	1
4	ball	SS 316	1
5	seat	15% Carbon+PTFE	4
6	stem	SS 316	1
7	stem seal	RPTFE	1
8	o-ring	VITON	1
9	stem packing	PTFE	1
10	gland	SS 304	1
11	belleville washer	SS 301	2
12	stem nut	SS 304	1
13	nut stop	SS 304	1
14	space washer	SS 304	1
15	lock saddle	SS 304	1
16	handle nut	SS 304	1
17	handle	SS 304	1
18	handle sleeve	Vinyl	1
19	stop pin	SS 304	1

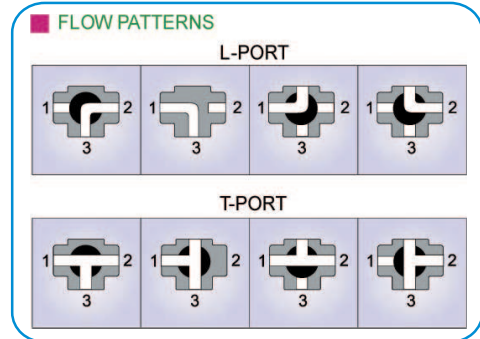
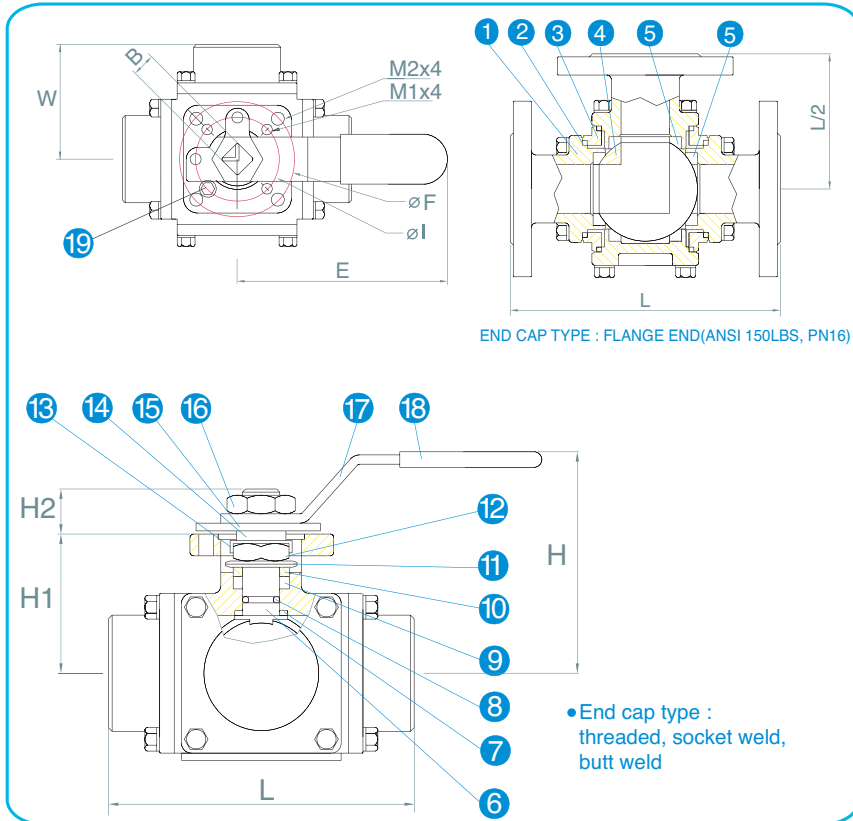

SIZE	B	øC	ød	E	H	H1	H2	øl	øF	L	M1	M2	W	ISO5211
1/4"	9			130	62	38.5	10	36	42	88	6.0	6.0	44	F03/F04
3/8"	9			130	62	38.5	10	36	42	88	6.0	6.0	44	F03/F04
1/2"	9			130	64	41	10	36	42	15	6.0	6.0	52.5	F03/F04
3/4"	11			165	82	49	13	42	50	112	6.0	7.1	55.5	F04/F05
1"	11			165	89	55	13	42	50	128	6.0	7.1	70	F04/F05
1 1/4"	14			205	98	63	17	50	70	140	7.1	9.2	64	F05/F07
1 1/2"	14			205	108	74	17	50	70	160	7.1	9.2	80	F05/F07
2"	17			325	140	93	22	70	102	192	9.2	11.4	96	F07/F10
2 1/2"	22	62	65	400	144					294				F10
3"	22	76	80	500	162					317				F10
4"	22	96	100	650	182					369				F10