

INDUSTRIAL BALL VALVES

2-PC HIGH PRESSURE SERIES



Series 20 / 40



FEATURES / SPECIFICATIONS:

- 2 Piece, 316 stainless construction
- High quality investment cast body
- Blowout proof stem design
- Full port design (no internal taper)
- Industrial/Chemical applications
- Standard locking handles
- ANSI B2.1, B16.34
- Size 1/4" to 1" rated at 2000psi WOG
- 1 1/4" to 2" rated at 1500psi WOG

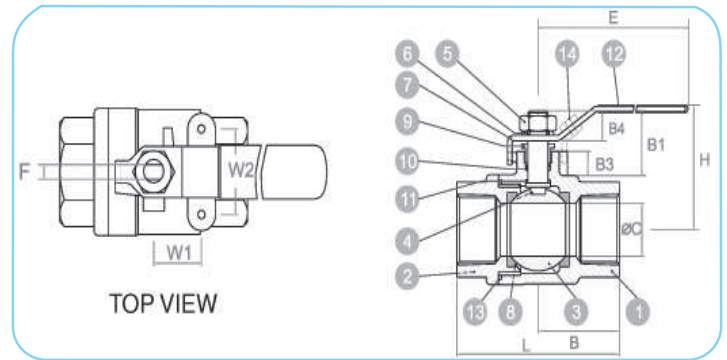

DIMENSIONS (mm)

size	B	B1	B8	B4	OC	E	F	H	L	W1	W2
1/4"	27.5	23	8	10	11.6	100	5.0	50	55	12.7	28.5
3/8"	27.5	23	8	10	12.7	100	5.0	50	55	12.7	28.5
1/2"	32.5	26	10	12	15.0	130	6.5	65	65	12.7	28.5
3/4"	37.0	26	11	12	20.0	130	6.5	74	74	22.4	35.0
1"	44.0	30	12	15	25.0	165	8.0	88	88	22.4	35.0
1 1/4"	51.0	37	12	15	32.0	165	8.0	102	102	25.4	38.1
1 1/2"	55.0	35	12	16	38.0	190	9.7	110	110	25.4	38.1
2"	62.5	31	10	16	50.0	190	9.7	125	125	25.4	38.1

Item	Part name	Material	Qty
1	body	ASTM A351 Gr.CF8M	1
2	cap	ASTM A351 Gr.CF8M	1
3	ball	SUS 316	1
4	stem	SUS 316	1
5	stem nut	SUS 304	1
6	stem washer	SUS 304	1
7	handle	SUS 304	1
8	seat	PTFE	2
9	gland	SUS 304	1
10	stem packing	PTFE	1
11	thrust washer	PTFE	1
12	handle sleeve	Vinyl	1
13	joint gasket	PTFE	1
14	locking device	SUS 304	1

BAR PSI

152	2200
138	2000
124	1800
110	1600
96	1400
83	1200
69	1000
55	800
41	600
28	400
14	200
0	0

PRESSURE & TEMPERATURE RATING

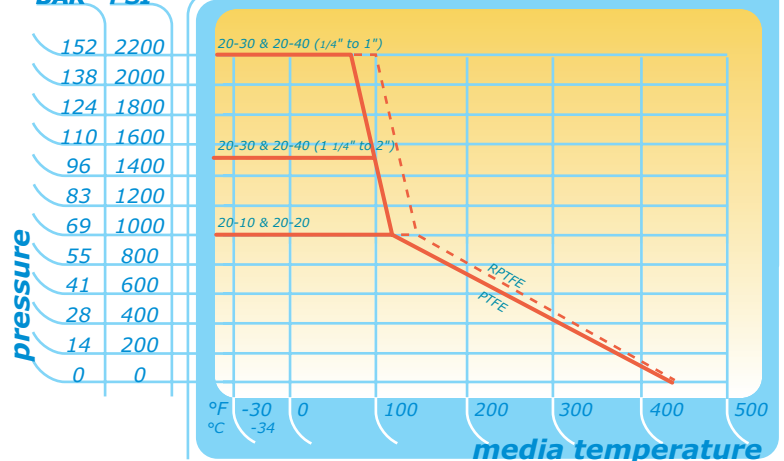

Series 20 / 40