

INDUSTRIAL BALL VALVES

2-PC SERIES



EA-207A-SE



FEATURES/SPECIFICATIONS:

- 316 Stainless Steel
- Economical 2 piece design
- 1000psi WOG rating
- High Quality, investment cast body
- Blowout proof stem design
- Industrial/Chemical applications
- Full-ported, NPT
- Reinforced PTFE seat/seals
- ANSI B16.34, ASTM-A351
- Size: 1/4"-2"

ITEM	PARTS NAME	MATERIAL	QTY
1	BODY	ASTM A351.GR.CF8M	1
2	END CAPS	ASTM A351.GR.CF8M	1
3	SEATS	PTFE + 15% G.F.	2
4	BALL	ASTM A351.GR.CF8M	1
5	STEM	SS316	1
6	JOINT GASKET	PTFE	1
7	GASKET	PTFE	1
8	SEAL	PTFE	1
910	PACKING GLAND	SS304	1
11	HANDLE	SS304	1
12	LEVER SPRING WASHER	SS304	1
13	LEVER NUT	SS304	1
	HANDLE COVER	VINYL	1

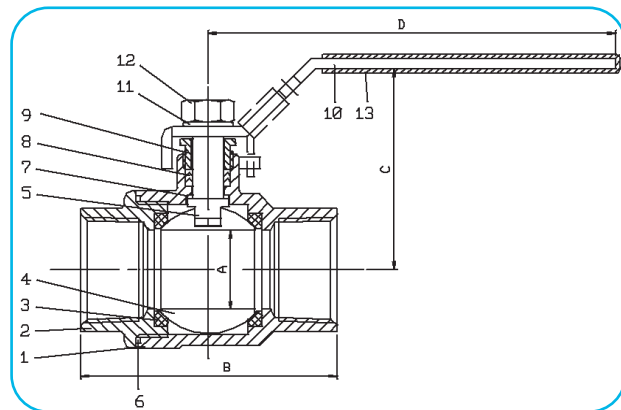

SIZE		A		B		C		D	
mm	inch	mm	inch	mm	inch	mm	inch	mm	inch
8	1/4	10	0.394	49.2	1.937	41.4	1.63	80	3.15
10	3/8	12.5	0.492	49.2	1.937	41.4	1.63	80	3.15
15	1/2	15	0.59	59	2.323	45	1.772	80	3.15
20	3/4	20	0.787	68.6	2.701	54.7	2.154	100	3.937
25	1	24.5	0.965	78.6	3.094	65.3	2.571	125	4.921
32	1 1/4	32	1.26	93.2	3.669	70.9	2.791	125	4.921
40	1 1/2	38	1.496	103.1	4.059	84	3.307	160	6.299
50	2	50	1.969	123.3	4.854	93.3	3.673	160	6.299

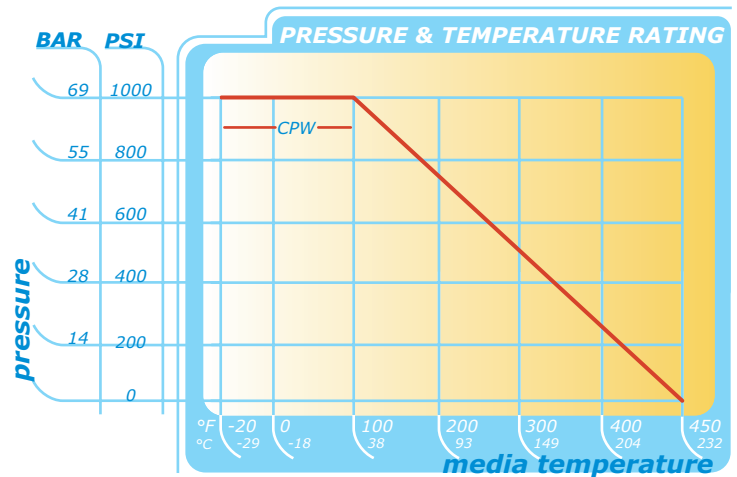

EA-207A-SE